

# **EDS-2000**

## **Outdoor PIR + MW detector**

### **INSTALLATION INSTRUCTIONS & USER MANUAL**

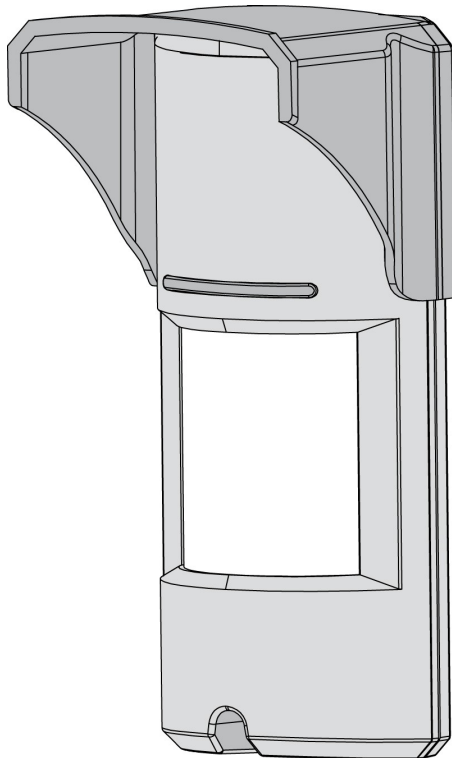



1	General.....	5
2	Features .....	5
3	Assembly description.....	6
4	Detection Pattern.....	7
5	Selecting mounting location.....	9
6	Detector Installation.....	10
7	Terminal Block Connections.....	12
7.1	Wire Size Requirements.....	12
8	Settings & Adjustments .....	13
8.1	Detection beam direction.....	13
8.2	Sensitivity and Range Adjustment.....	13
8.3	Pet immunity setting .....	14
8.4	Indications setting.....	15
9	Operation.....	16
10	Test procedure.....	17
11	Specifications.....	18



## 1 **General**

The EDS-2000 is unique Passive Infra-Red and Microwave detector for outdoor and harsh environment applications.

The EDS-2000 is designed for outdoor usage in most severe and extreme acclimate conditions that may also accommodate pets.

High reliability is achieved by combining both dual tech hardware with highly sophisticated software, reducing false alarms alerts to zero.

It comprises of optics and advanced MW detection inside stylist rigid plastic body.

This special optics combined with MW Doppler sensor assures elimination of “false alarms” while maintaining high security standards for the detection of human intruders into protected area.

The detection sensitivity and range is controlled by potentiometer allowing fine tuning, so that the effective pattern will be set for every installation environment and protection site.

The EDS-2000 is designed to protect large areas and can easily be installed on walls in order to provide a solid protection of the area while rejects interferences from birds and small animals due to “PET MASK” optics.

## 2 **Features**

- MW detection based on Doppler concept.
- N.O. & N.C. relays switched at the same time.
- Height installation calibrations free, from 1.8m to 2.4m (5.9 ft to 7.9 ft)
- Selectable Pet immunity up to 36kg (80 lbs)
- PIR sensitivity adjustment.
- MW intensity selection.
- Temperature compensation.
- Micro controller signal processing.
- Front and back tamper protection.
- Unique waterproof and seal plastic design.
- Detection Range: Up to 15m (49 ft)
- Detects human intruders walking or running.
- No maintenance required.
- High RFI/EMI Immunity.
- Protection from: direct sunlight, wind up to 30 m/sec, snow and rain, small animals, removing the top cover, housing pulling out or destruction

### 3 **Assembly description**

The EDS-2000 is a robust yet small detector which includes big indication led prism that can be easily observed from long distance. Having a back metal bracket, the EDS-2000 can be easily mounted to walls using mounting screws (supplied).

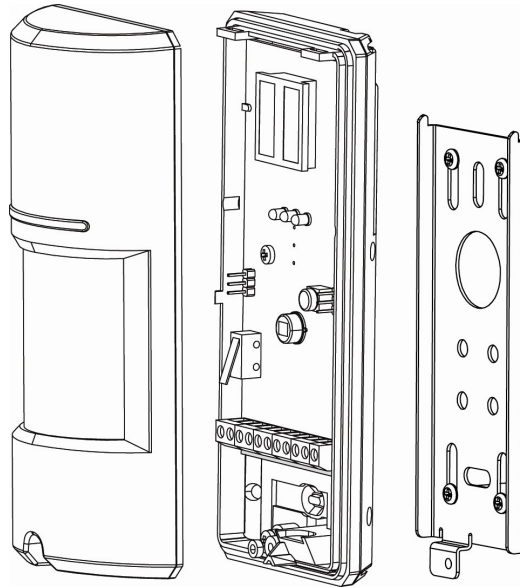

In addition, there is an option to mount the EDS-2000 by using a mounting arm – not supplied with product. (For details contact Crow)

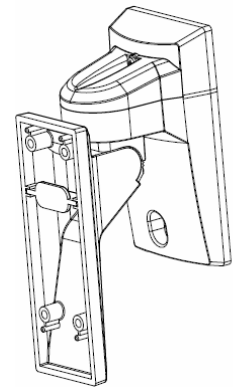

The EDS-2000 is combined of two detection elements:

- PIR element
- MW element

The following drawing shows all internal elements:

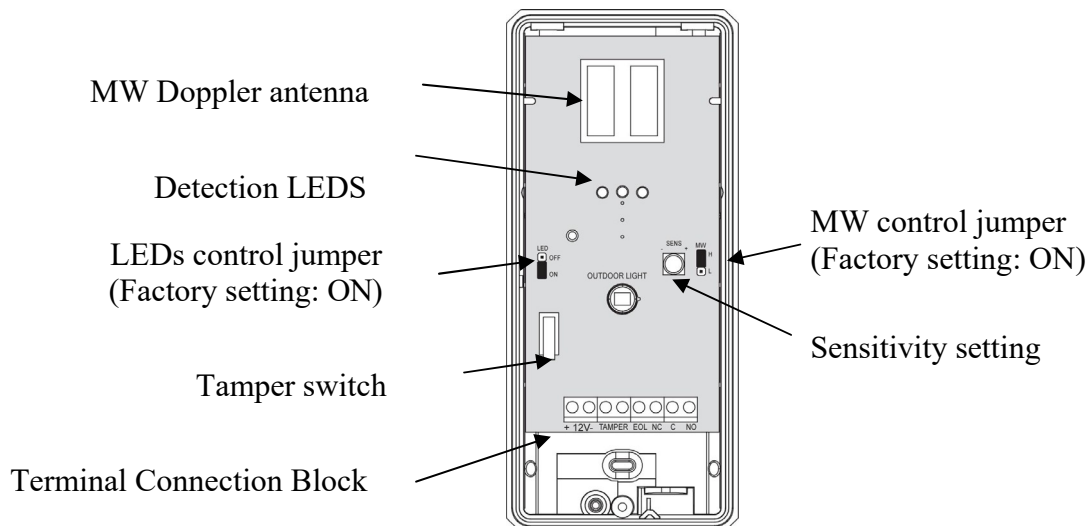

#### 4 **Detection Pattern**

The EDS-2000 has a 90° top view PIR and MW detection pattern with over 15m (49 ft) detection distance (when installed at 2.4m (7.9 ft) above the ground surface).

#### Standard Lens

TOP VIEW

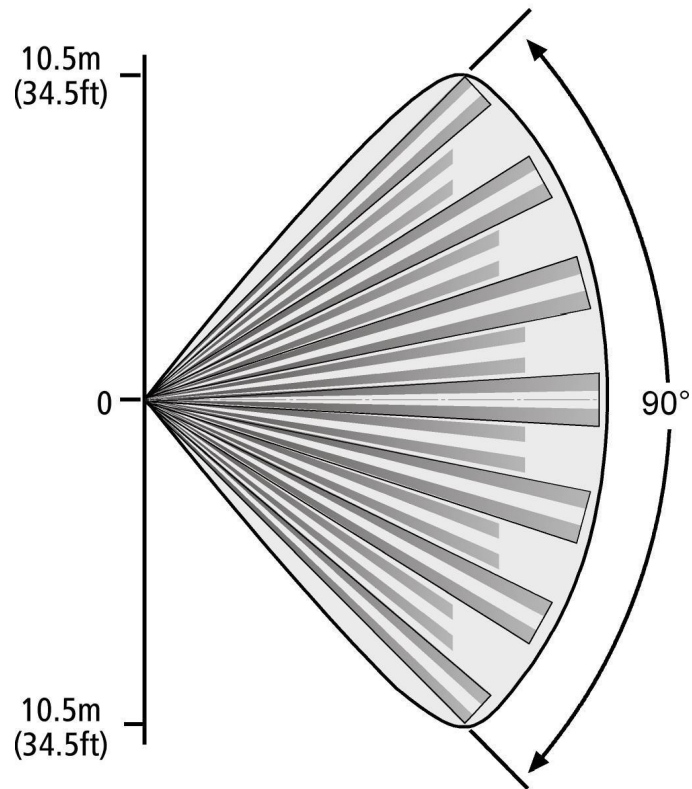

SIDE VIEW

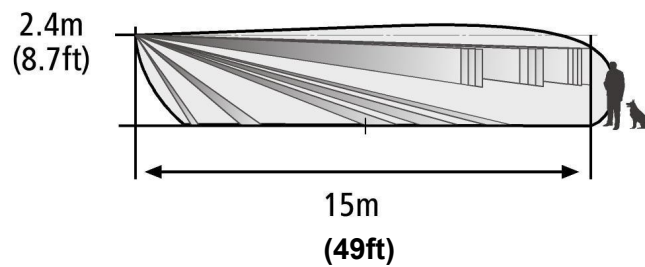

When using a curtain lens (optional, sold separately) the EDS-2000 has a 3° top view PIR and MW detection pattern with over 20m (65 ft) detection distance (when installed at 2.4m (7.9 ft) above the ground surface).

Curtain Lens

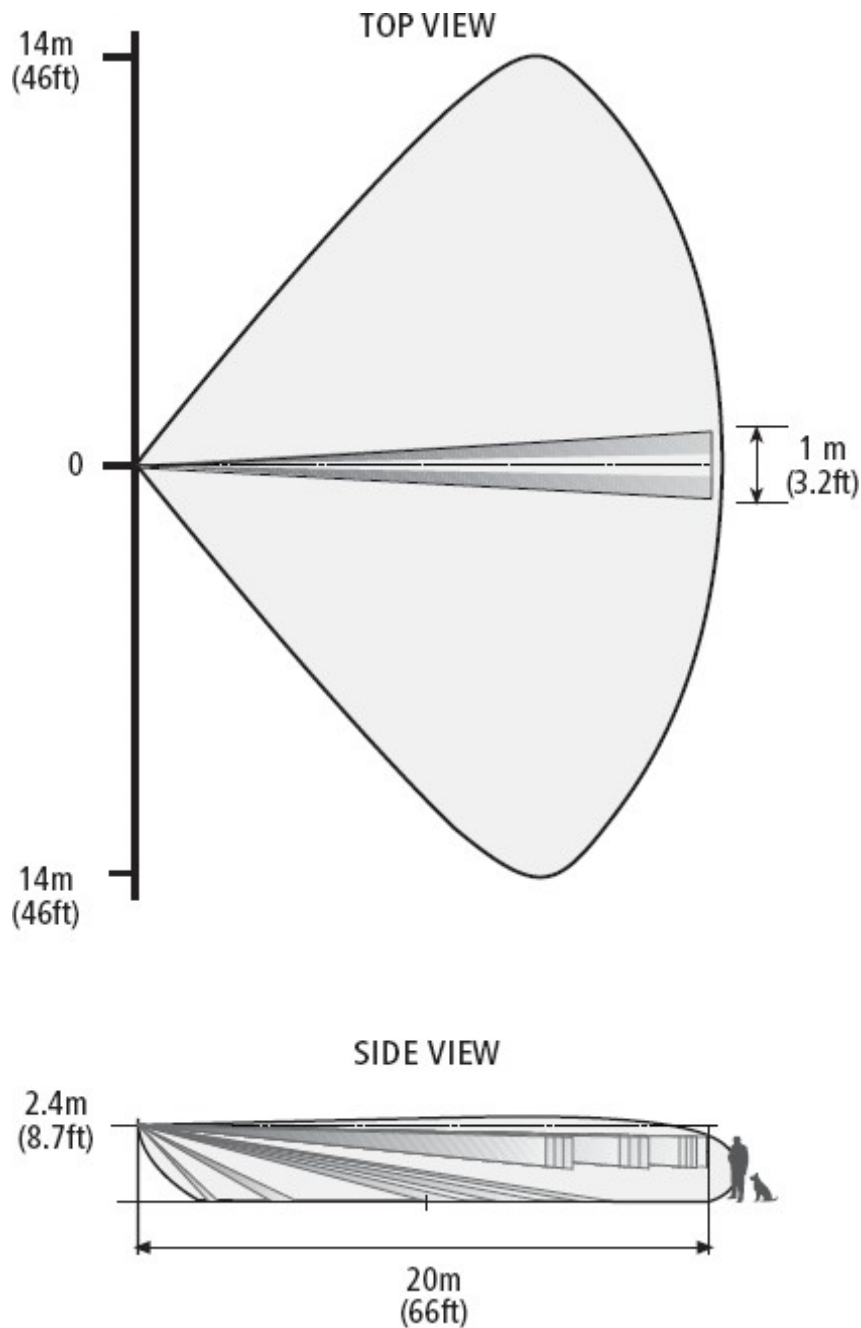

Having MW movement detection combined with PIR detection beam, the EDS-2000 can differentiate between pets and human bodies and alert accordingly. By having both PIR detection beam and MW crossing an object it will be defined as intrusion, causing an alarm. In case only MW detects motion and PIR does not, no alarm will be generated.



## 5 Selecting mounting location

The installation of the EDS-2000 requires straight and solid base for the detector and setting of front panel against the center of protected area.

The protected area must be free from obstacles like walls, fences, trees, ditches and other microwave detectors, as well as systems of anti-intrusion surveillance.

The bracket provides EDS-2000 installation on a wall. The wall should be leveled.

Choose a location most likely to intercept an intruder according to detection pattern on page 8.

Avoid the following Installation Locations:

- Facing direct sunlight.
- Facing areas subject to rapid temperature changes.
- Wall angle of more than 10° from perpendicular line.
- Mounting at more than 10° Deviation from horizontal line.
- Facing metal doors.
- Do not install near direct source of heat or air gust.
- Clear all physical obstacles from the detection area (e.g. Plants, laundries, etc.)
- Clear all light reflecting surfaces from the detection area, as well as water puddles.
- Avoid installation on the following types of ground:  
Thick vegetation, Grass (un-mown), Water, Sand and Metal.

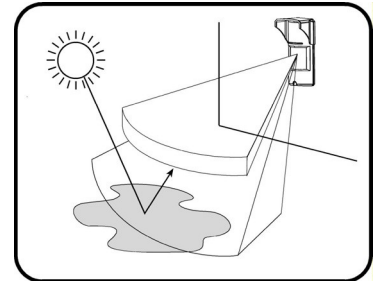
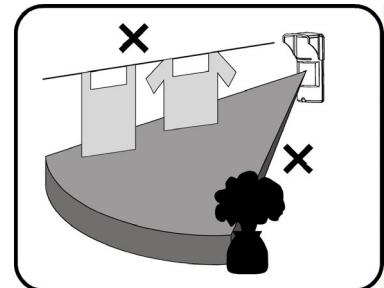
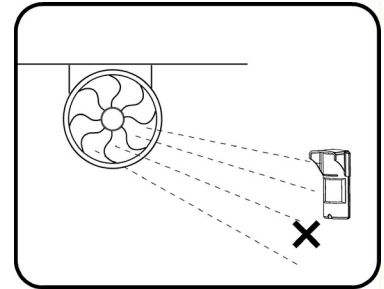

### NOTE:

Recommended installation height is 2.1m (6.9ft).

The PIR sensor detects motion crossing the beam; it is less sensitive detecting motion towards the detector.

The EDS-2000 performs best when provided with a constant and stable environment.

In order to ensure suitable operation of the EDS-2000 type of ground should be one of the following: Asphalt concrete, Cement, Soil, Clay, Gravel or Grass (mown).

## 6 **Detector Installation**

**Important!** Prior to installation, read both “Operation” and “Selecting the mounting location” sections carefully.

1. Install the detector in such manner that the intruder is most likely to cross the detection area from side to side.

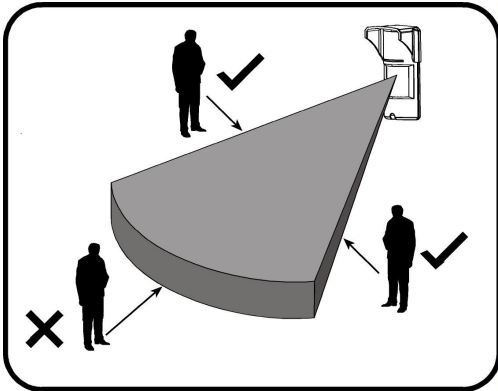

2. The detector is to be installed at height of 1.8 to 2.4 meters (5.9 to 7.9 ft)

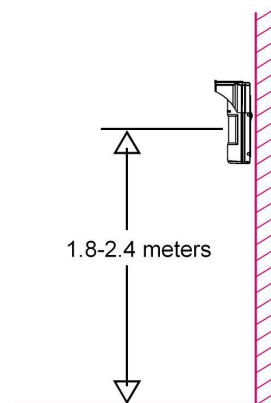

3. Make sure to attach the metal bracket to a leveled straight and firm wall, leaving 10cm (4 inches) from the top and 10cm (4 inches) from both sides, for easy installation and maintenance.

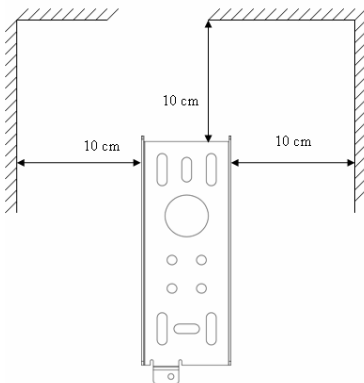

4. Placing the detector on perpendicular wall is required for guarding a side window opening.

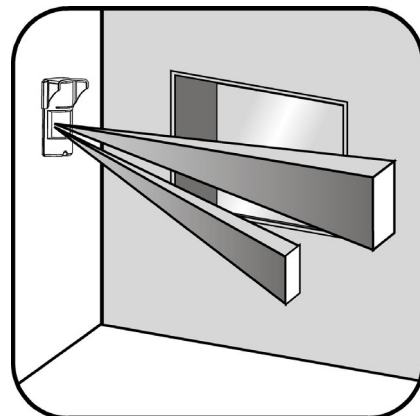

5. Open the detector unwinding the bottom screw.

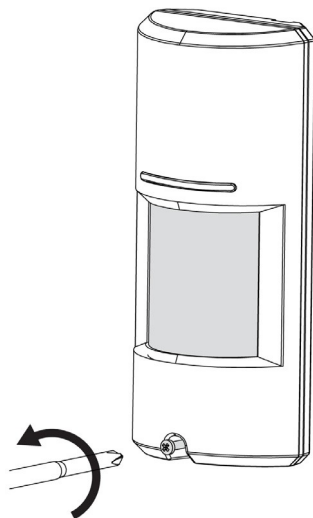

6. Release the rear metal bracket by unwinding internal bottom screw.

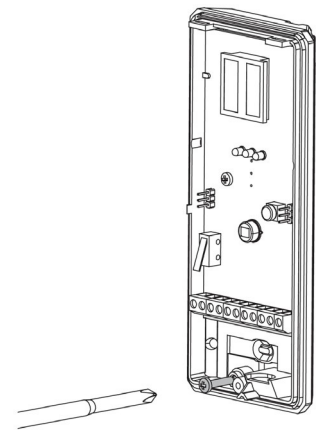

7. Release the detector body from the metal bracket by pulling to front and up.

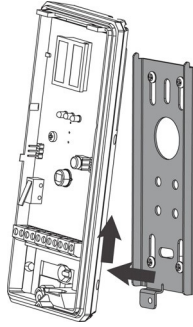

8. Attach the rear bracket to the wall using mounting screws or metal bands.

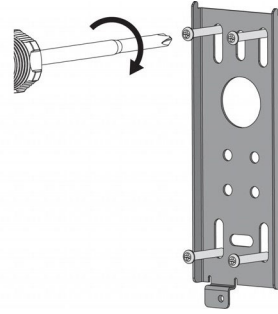

9. Slide the wires from the rear side internally.

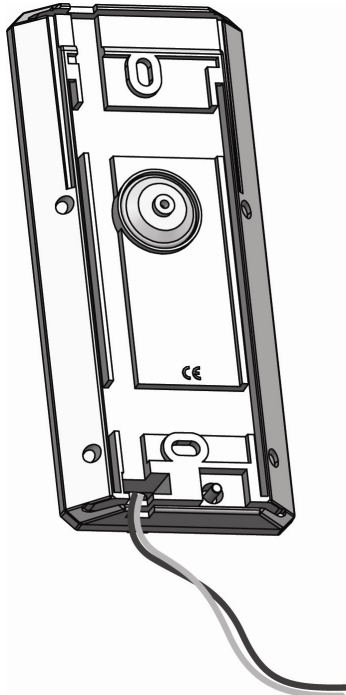

10. Attach the sealing sponge pad to the wire opening from the rear side after the wires connection and prior to final product affixing to the mounted bracket.

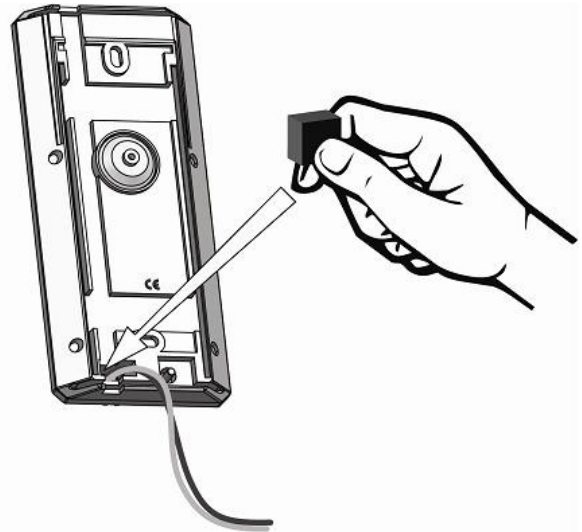

11. Place the detector on the mounting bracket from top side down and then lock the screw at the bottom.

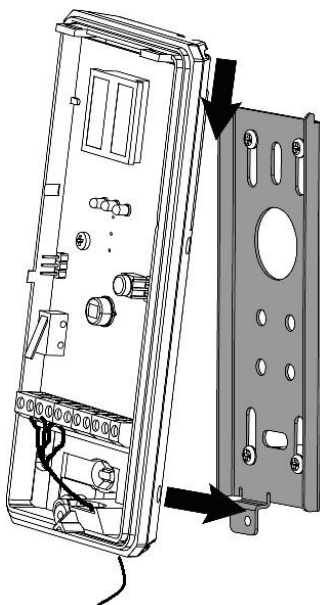

12. Select relevant PET immunity level by disassembling PET filter (supplied and assembled) or using the filter.  
(Refer to paragraph 8.3 for more details)

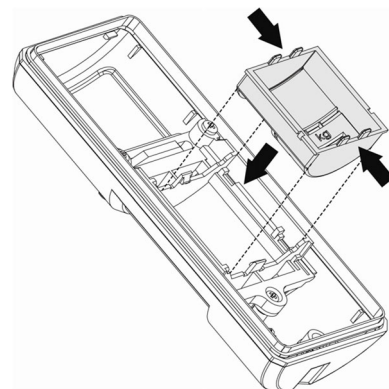

## 7 Terminal Block Connections

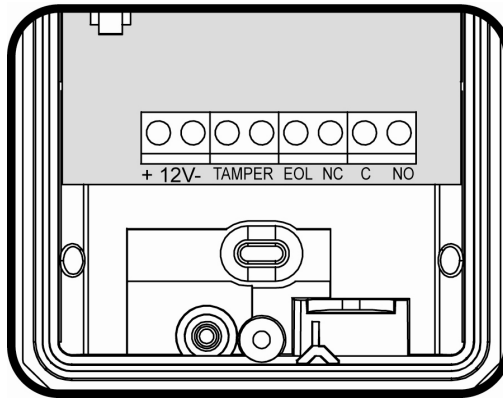

**Terminal 1 - Marked “+” (+12V)** - Connect to a positive Voltage of 9.6 -16Vdc source (usually from the alarm CP)

**Terminal 2 - Marked “-” (GND)** - Connect to the ground of the CP.

**Terminals 3 & 4 - Marked “TAMPER”** - If a Tamper function is required connect these Terminals to a 24-hour normally closed protective zone in the CP.

If the top cover of the detector is opened or the detector is detached from installation wall, an immediate alarm signal will be sent to the CP.

**Terminal 5 - Marked “EOL”** - End of line – optional terminal for end of line resistors connections.

**Terminals 6, 7 & 8 - Marked “NC / C / NO”** - These are the output relay contacts of the detector. Connect to a normally closed or normally opened zone in the control unit. When an intruder is detected, alarm relays (N.C. and N.O.) will switch for 1.8 sec.

### 7.1 **Wire Size Requirements**

Use #22 AWG or larger wires. Use the following table to determine required wire gauge and length.

Wire Length [m]	205	310	510	870
Wire Length [ft.]	800	1200	2000	3400
Wire Gauge [#]	22	20	18	16

## 8 Settings & Adjustments

### 8.1 Detection beam direction

The EDS-2000 detection beam direction is fixed. As a result, it is recommended to face the intrusion area with the detector.

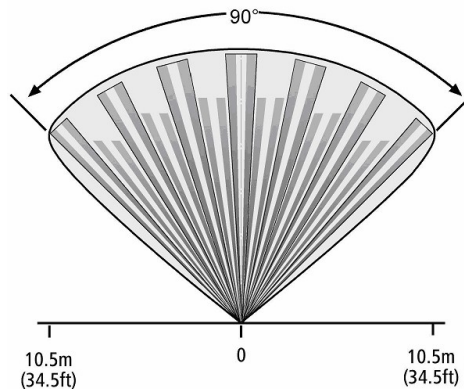







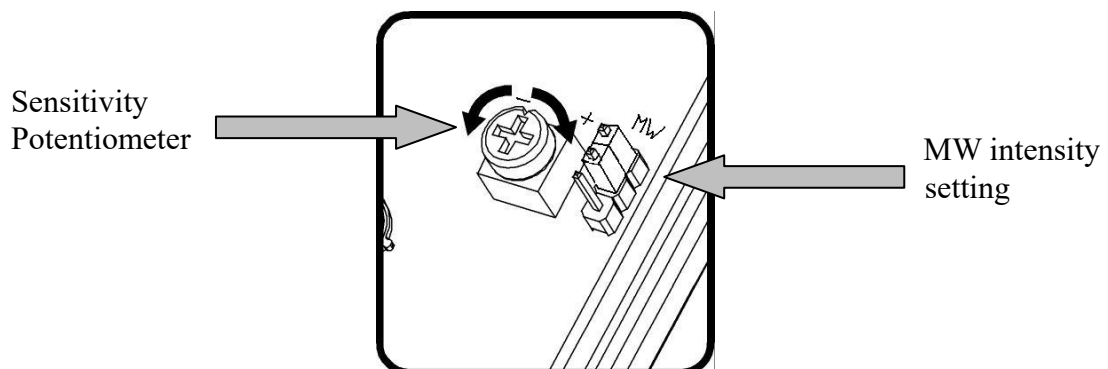





### 8.2 Sensitivity and Range Adjustment

There are 6 groups of environments for which different settings are required:

- Low risk: very stable environment without interference like parking garage, under roof parking space, playground, football court, service road, etc.
- Risk: Stable environment with some trees, bushes, flowerpots, planters.
- High risk: Unstable environment with different types of vegetation and grass and puddles.
- Very high risk: Unstable environment with winds and small pets, rats, mice, birds.
- Noisy area: Unstable environment with vegetation and water sources like swimming pool, lake, canal, weed as well as small pets like cats and rabbits.
- Extremely Noisy area: Very unstable environment subjected to wind, snow, rain, with vegetation, water and large pets like dogs.



The sensitivity adjustment is performed by setting a potentiometer and MW jumper as follows (using clock needle positioning):

Environment type	Potentiometer position	MW jumper position
Low risk	4 o'clock 	H 
Risk	12 ~ 3 o'clock 	H 
High risk	3 ~ 4 o'clock 	L 
Very high risk	12 ~ 3 o'clock 	L 
Noisy area	9 ~ 12 o'clock 	L 
Extremely Noisy area	8 o'clock 	L 

**Note:** Adjust sensitivity according to environmental conditions!

### 8.3 Pet immunity setting

The EDS-2000 has a detachable Pet immunity filter. As such the Pet immunity level may vary between:

1. 36kg (80 lbs) with pet immunity filter assembled
2. 15kg (33 lbs) if no pet immunity filter is used.

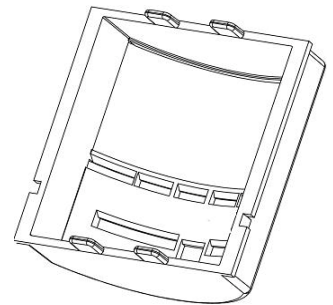

The installer is to select the requested Pet immunity level.

The filter is to be installed according to the following orientation:

This side up!

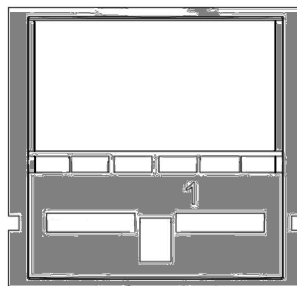

## 8.4 Indications setting

The EDS-2000 has 3 LEDs that each points at different indication:

1. Green LED indicates PIR detection.
2. Yellow LED indicates MW detection.
3. Red LED - alarm indication (logic AND of both MW and PIR).

The installer has an option to control LEDs operation, using the LED control jumper, between “ON” and “OFF”.

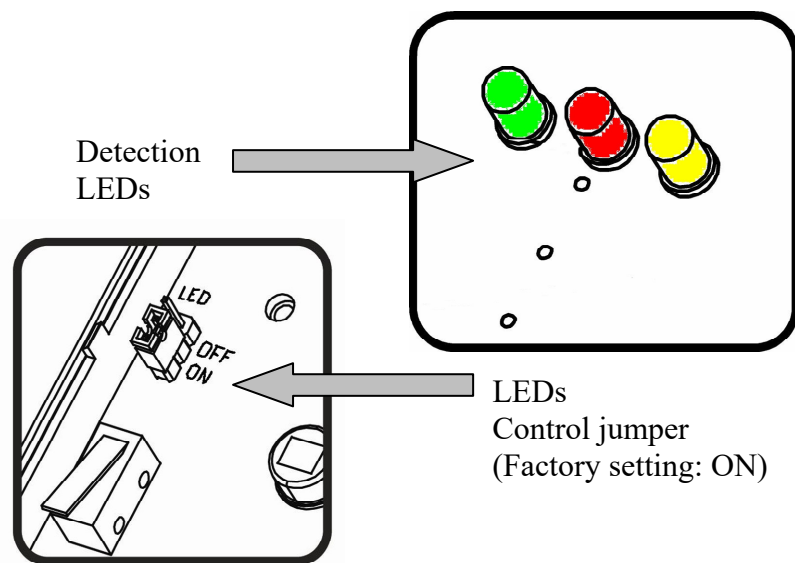

- Place the top cover to the base and close it using the bottom screw.

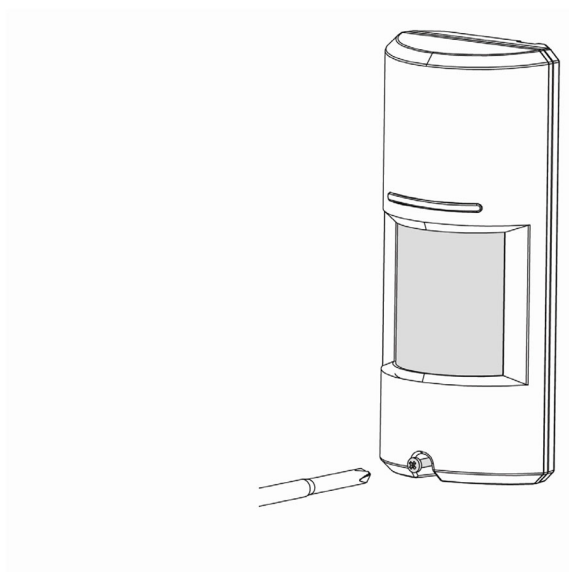

## 9 **Operation**

**Note!** Connect the EDS-2000 to a positive Voltage output of 9.6 -16VDC source.

Use only a listed power limited source.

The detector shall be provided with minimum of 4 hours of standby power from either a listed compatible control unit or power supply.

- The detector is automatically operated once connected to power.
- The LEDs start flashing one at a time (side to side) for 30 seconds during the warm-up period and after that it will turn off.
- At this time the detector is ready for operation.



## 10 Test procedure

### Walk Test

Make sure LEDs control is set to "ON"

Allow 30 seconds of warm up time.

Make sure that the protected area is cleared of all people.

Start walking across the detection zone.

Look at the LEDs whenever motion is detected - all LEDs are turned ON.

Allow 5 sec. between each test for the detector to stabilize.

Upon installation, the unit should be thoroughly tested to verify proper operation.

Walk across the entire area where coverage is desired. Should the coverage be incomplete, readjust sensitivity or relocate the detector.

Once coverage is as desired the LEDs may be disabled.

***NOTE:*** *Walk Test procedure should be conducted, at least once a year, to confirm proper operation and coverage of the detector.*

## 11 Specifications

<b>Detection Method</b>	PIR AND MW
<b>Microwave Frequency</b>	X-band (9.9GHz / 10.525GHz / 10.687GHz) K-band (24.125 GHz)
<b>Power Input</b>	9.6 to 16Vdc, 120 mA
<b>Current Draw</b>	<b>Active:</b> 24mA (±5%) <b>Standby:</b> 21mA (±5%)
<b>Temp Compensation</b>	Yes, Dual slop temperature compensation
<b>Alarm Period</b>	2 sec (±0.5sec)
<b>Alarm Outputs</b>	Form C (NC, NO, Common) 28Vdc 0.1 A with 10 Ohm
<b>Tamper Switch(s)</b>	Two Switches N.C 28Vdc 0.1 A with 10 Ohm Series protection resistors Opens when cover is removed from unit's base
<b>Warm up Period</b>	30sec (± 5sec)
<b>LED Indicator</b>	All LEDs are ON during ALARM
<b>RF Immunity</b>	10 V/m plus 80% AM from 80 MHz to 2GHz
<b>ElectroStatic Immunity</b>	6kV contact, 8kV air
<b>Transient Immunity</b>	1kV
<b>Operation Temp</b>	-35°C ~ +55°C (-31°F ~ 131°F)
<b>Dimensions</b>	160mm x 70mm x 45mm (6.9" x 2.8" X 1.8")
<b>Weight</b>	210gr. (0.5 lbs)
<b>European directives</b>	RTTE directive:1999/5/EC EMC directive: 89/336/EEC Low Voltage directive: 73/23/EEC RoHS directive: 2002/95/EC
<b>European standards requirements:</b>	EN300 440-2 EN301 489-1 EN50130-4 +A1 +A2 EN61000-6-3+A11 EN60950-1 EN50131-1 / EN50131-2-4 / EN50130-5
<b>USA &amp; Canada</b>	47CFR part 15, subpart C, section 15.245 47CFR part 15, subpart RSS210 ICES-003
<b>Protection Degree</b>	IEC 60529: IP 65

\* Specifications are subject to change without prior notice.

## **CROW LIMITED WARRANTY**

(CROW) warrants this product to be free from defects in materials and workmanship under normal use and service for a period of two years from the last day of the week and year whose numbers are printed on the printed circuit board inside this product.

CROW's obligation is limited to repairing or replacing this product, at its option, free of charge for materials or labor, if it is proved to be defective in materials or workmanship under normal use and service. CROW shall have no obligation under this Limited Warranty or otherwise if the product is altered or improperly repaired or serviced by anyone other than CROW. There are no warranties, expressed or implied, of merchantability or fitness for a particular purpose or otherwise, which extend beyond the description on the face hereof. In no case shall CROW be liable to anyone for any consequential or incidental damages for breach of this or any other warranty, expressed or implied, or upon any other basis of liability whatsoever, even if the loss or damage is caused by CROW's own negligence or fault.

CROW does not represent that this product can not be compromised or circumvented; that this product will prevent any person injury or property loss or damage by burglary, robbery, fire or otherwise; or that this product will in all cases provide adequate warning or protection. Purchaser understands that a properly installed and maintained product can only reduce the risk of burglary, robbery or other events occurring without providing an alarm, but it is not insurance or a guarantee that such will not occur or that there will be no personal injury or property loss or damage as a result. Consequently, CROW shall have no liability for any personal injury; property damage or any other loss based on claim that this product failed to give any warning. However, if CROW is held liable, whether directly or indirectly, for any loss or damage arising under this limited warranty or otherwise, regardless of cause or origin, CROW's maximum liability shall not in any case exceed the purchase price of this product, which shall be the complete and exclusive remedy against CROW.



**CROW ELECTRONIC ENGINEERING LTD.**

**12 Kineret St.**  
Airport City, 70100 Israel  
Tel. +972 3 9726000  
Fax. +972 3 9726001  
sales@crow.co.il  
support@crow.co.il  
www.thecrowgroup.com

**CROW LATIN AMERICA USA INC.**

7200 NW 19 st.  
Suite 307  
Miami FI 33126, USA  
Tel. +305 513 4001  
Fax. +305 513 4005  
rejane@crowlatinamerica.com  
www.crowlatinamerica.com

**ARROWHEAD ALARM PRODUCTS**

344B, Rosedale Road  
Park Farm Industrial Estate  
Albany, Auckland  
New Zealand  
Tel. +64 9 414 0085  
Fax. +64 9 414 0088  
www.aap.co.nz

These instructions supersede all previous issues in circulation prior to May 2020.