

FW2-MAG-8F

FW2-MAG-9F

FW2 MAGNETIC CONTACT



INSTALLATION INSTRUCTIONS

P/N 7101590 REV. D

INTRODUCTION

The FW2-MAG is an advanced magnetic contact sensor with integrated RF transceiver designed to be a fully supervised low-current device. The FW2-MAG is a part of the FREEWAVE2 which is a supreme wireless line of devices that uses an advanced 2way RF transceiver combined with an intelligent communication protocol. A built-in reed switch and/or an external wired input may be applied in this device. To maximize security, an 8.2k end-of-line resistor is monitored on the external wired input. FW2-MAG uses smart message control, which verifies that all messages are successfully transmitted, so that no intrusion event will be uninformed to the system. Each FW2-MAG has a unique factory set ID code (24bit) which by registration is set into memory of the paired FREEWAVE2 TRANSCEIVER, enabling more secured communication and devices to be remotely controlled from a specific transceiver.

FEATURES

- State-of-the-art 2 way wireless security system
- Freewave2 advanced & secured RF protocol
- Low current Technology
- Powered by a single 3V Lithium battery
- Battery life: more than 5 years
- Frequency:
 - 868.35MHz, 868.85MHz (FW2-MAG-8F) or 916.5MHz (FW2-MAG-9F)
- Contact Open/Close transmission
- Tamper Open/Close transmission
- Supervision transmission
- Battery status send on every transmission
- Range up to 500m on open space.
- Unique ID number
- Front and back tamper.
- Alarm trigger either by the internal reed switch and / or by wired terminal
- Wired terminal with E.O.L 8K2 resistor.

OPERATION

The Wireless Magnetic detector transmits the following events data:

SUPERVISION - a periodical transmission every 2 min. indicates detector's presence.

ALARM - Alarm transmission triggered by intrusion detection by REED SWITCH and WIRE input.
(Selectable, See section 8: SETTING THE OPERATION MODE).

LOW BAT - Whenever the battery reaches a pre-set low level (~2.4V) Battery Low signal will be sent with the next scheduled message (Supervisor, Alarm, etc.).

TAMPER - Whenever the FW2-MAG cover is removed or tore off wall, a message will be transmitted with "Tamper" signal.

FIG. 1 - REMOVAL OF FRONT COVER

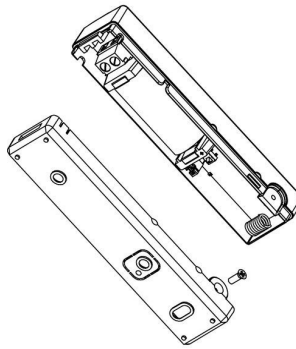

FIG. 2 - BATTERY PLACEMENT

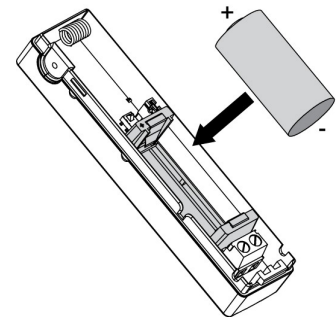
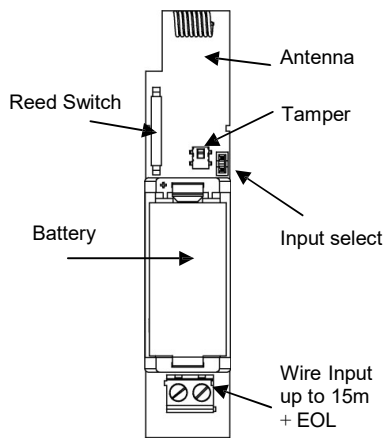

Fig. 3 - CIRCUIT LAYOUT



SETTING THE OPERATION MODE

There are 3 operational modes for the FW2-MAG and it should be configured during the power-up (battery placing)

1. Internal Reed Switch only:
Jumper is connected and Wired Terminal open.
2. External Reed switch only:
Jumper is connected and external reed switch closed with resistor 8K2.
Note: to return to internal reed installer should reset device (battery remove and replace)
3. Both internal and external reed switches:
Jumper is **NOT** connected
Note: At this mode if one of the reed switches is open an "Open zone" message will be transmitted.

ID REGISTRATION

Refer to the system transceiver's installation instructions and follow the procedure given there for "learning" detector IDs. Place battery as instructed & wait until start up LED stops blinking.

Make sure that the transceiver is on learning mode according to control panel installation instruction. Generate a transmission by pressing and releasing tamper switch - this will start the "learn" data transmitting by the device to the control panel transceiver.

Note the LED indications on the device:

- **Green/Red LED flashes alternately** - for 5 sec Magnet was registered successfully cover may be closed only after verification with control panel.
- **Green LED blinks periodically** - Device was not signed into FW2-TRANSCIVER. Repeat registration process
- **Red LED blinks** - for over 20sec Battery voltage is critically low. Replace battery

SELECT MOUNTING LOCATION

It is recommended to mount FW2-MAG vertically on a flat area to get maximum range. As the detector is a wireless transceiver, and in order to take full advantage of it's sophisticated operation, do not install the detector in areas where large metal objects could interfere with the transmission of signals. It is recommended to attach transmitter to the fixed frame and the magnet to the moveable part (door or window), as shown on section 14. Installation is not allowed on a ferromagnetic surface.

For detector installation it is recommended to use SCREW 3x30 PH. FLAT HEAD
CAUTION: using a different or a bigger screw can damage the electronic board.

RSSI - RF SIGNAL INDICATION

The FREEWAVE2 control panel has "RF Signal Strength Indication" (RSSI) for each transceiver in order to help the installer to define the best location for the detector from RF perspective. The indication value is between 10 and 100, where 100 is the best RF received signal. If the RSSI indication value is less than 30, it is a sign for a weak RF link and it is recommended to find a better installation for the FW2-MAG.

NOTE: Supported only on selected Crow CP.

CAUTION !!!

RISK OF EXPLOSION IF BATTERY IS REPLACED BY DIFFERENT TYPE/MODEL.
DISPOSE USED BATTERIES ACCORDING TO ITS INSTRUCTIONS

The battery must be replaced by 3V Lithium battery Size 2/3A, Models such as: VARTA CR123A or GP CR123A

FIG. 4 - KNOCKOUT HOLES

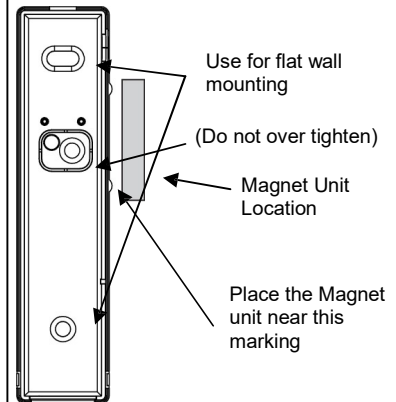

MOUNTING THE DETECTOR

- To remove the front cover, unscrew the holding screw, insert a flat screwdriver in the slot between the front and the bottom while pushing and twisting it gently until the front cover is disengaged. (Fig. 1)
- Mount the detector base: place all 3 screws and make sure you tighten the tamper screw (the middle screw) easily, so the back tamper switch will press the switch successfully when PCB is placed back - over winding may result in false mechanical adaptation and lack of tamper press.
- Mount the Magnet Unit near the Marking.
- Place the CR123A BAT according to the right polarity
- Place the cover by inserting it back in the appropriate closing pin and screw the holding screw.

TAMPER TRANSMISSION TEST

Pressing and releasing the tamper (push button) enables the TAMPER transmission test feature. Verify the Control Panel indicates "Zone Tamper open" and TROUBLE LED is ON. Close the Tamper and verify the Control Panel Indicates ZONE TAMPER OPEN is restored and TROUBLE LED is OFF. In some control panels READY LED will turn OFF when tamper is open and ON when closed. Transmission can also be reviewed on the transceiver unit as a rapid Red-Green-LED blink.

EXTERNAL MAG

It is optional to use additional magnet units connected to the MAG terminal input. This connection is protected by End Of Line resistor value 8.2Kohm. Alarm transmission, triggered by intrusion detection at WIRE terminal input, provides signals of door/window open/close up to 15m. Connect two wires communication cable to the MAG terminal block inputs. See Fig.3.

FCC & IC STATEMENT

FCC ID: NFC-FW2MAG9F
IC: 8164A-FW2MAG9F

This device complies with FCC Rules Part 15 and with Industry Canada license-exempt RSS standard(s). Operation is subject to two conditions: (1) This device may not cause harmful interference, and (2) this device must accept any interference that may be received or that may cause undesired operation.

Canada: Le présent appareil est conforme aux CNR d'Industrie Canada applicables aux appareils radio exempts de licence. L'exploitation est autorisée aux deux conditions suivantes: (1) l'appareil ne doit pas produire de brouillage, et (2) l'utilisateur de l'appareil doit accepter tout brouillage radioélectrique subi, même si le brouillage est susceptible d'en compromettre les coûts et le fonctionnement.

WARNING:
Changes or modifications to this equipment not expressly approved by the party responsible for compliance (Crow Electronic Engineering Ltd.) could void the user's authority to operate the equipment.

CROW ELECTRONIC ENGINEERING LTD. ("Crow") - WARRANTY POLICY CERTIFICATE

This Warranty Certificate is given in favor of the purchaser (hereunder the "Purchaser") purchasing the products directly from Crow or from its authorized distributor.
Crow warrants these products to be free from defects in materials and workmanship under normal use and service for a period of 24 months from the last day of the week and year whose numbers are printed on the printed circuit board inside these products (hereunder the "Warranty Period"). Subject to the provisions of this Warranty Certificate, during the Warranty Period, Crow undertakes, at its sole discretion and subject to Crow's procedures, as such procedures are from time to time, to repair or replace, free of charge for materials and/or labor, products proved to be defective in materials or workmanship under normal use and service. Repaired products shall be warranted for the remainder of the original Warranty Period. All transportation costs and in-transit risk of loss or damage related, directly or indirectly, to products returned to Crow for repair or replacement shall be borne solely by the Purchaser.
Crow's warranty under this Warranty Certificate does not cover products that is defective (or shall become defective) due to: (a) alteration of the products (or any part thereof) by anyone other than Crow; (b) accident, abuse, negligence, or improper maintenance; (c) failure caused by a product which Crow did not provide; (d) failure caused by software or hardware which Crow did not provide; (e) use or storage other than in accordance with Crow's specified operating and storage instructions.
There are no warranties, expressed or implied, of merchantability or fitness of the products for a particular purpose or otherwise, which extend beyond the description on the face hereof.
This limited Warranty Certificate is the Purchaser's sole and exclusive remedy against Crow and Crow's sole and exclusive liability toward the Purchaser in connection with the products, including without limitation - for defects or malfunctions of the products. This Warranty Certificate replaces all other warranties and liabilities, whether oral, written, (non-mandatory) statutory, contractual, in tort or otherwise.
In no case shall Crow be liable to anyone for any consequential or incidental damages (inclusive of loss of profit, and whether occasioned by negligence of the Crow or any third party on its behalf) for breach of this or any other warranty, expressed or implied, or upon any other basis of liability whatsoever. Crow does not represent that these products can not be compromised or circumvented; that these products will prevent any person injury or property loss or damage by burglary, robbery, fire or otherwise; or that these products will in all cases provide adequate warning or protection.
Purchaser understands that a properly installed and maintained product may in some cases reduce the risk of burglary, fire, robbery or other events occurring without providing an alarm, but it is not insurance or a guarantee that such will not occur or that there will be no personal injury or property loss or damage as a result.
Consequently, Crow shall have no liability for any personal injury; property damage or any other loss based on claim that these products failed to give any warning.
If Crow is held liable, whether directly or indirectly, for any loss or damage with regards to these products, regardless of cause or origin, Crow's maximum liability shall not in any case exceed the purchase price of these products, which shall be the complete and exclusive remedy against Crow.

INSTALLATION

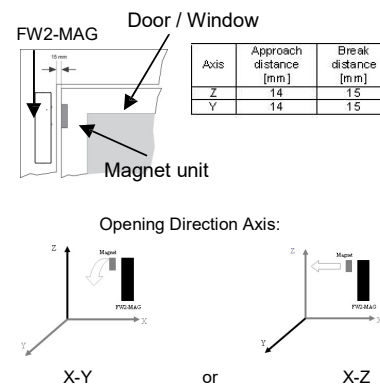

BATTERY REPLACEMENT

- Remove the front cover.
- Pull out the old battery.
- Install a new battery according to polarity marking.
- After assembling the battery the LED will flash Green then Red alternately for 45 seconds. During this time the detector does not function, wait until the LED stop flashing.
- Press tamper for 2 sec and then release it.
- Note LED indications:
Green/Red LED flashes 6 times alternately:
The detector was successfully registered in system. The cover may be placed back and closed.

Green LED blinks 20 times:

No response from Transceiver / device was not assigned on CP - Repeat installation procedure.

Red LED blinks continually (over 20 sec):

Battery voltage is critical low device won't function - Replace battery.

FCC & IC STATEMENT (Continue)

NOTE: The digital circuit of this device has been tested and found to comply with the limits for a Class B digital device, pursuant to part 15 of the FCC Rules. These limits are designed to provide reasonable protection against harmful interference in a residential installation. This equipment generates uses and can radiate radio frequency energy and, if not installed and used in accordance with the instructions, may cause harmful interference to radio communications. However, there is no guarantee that interference will not occur in a particular installation. If this equipment does cause harmful interference to radio or television reception, which can be determined by turning the equipment off and on, the user is encouraged to try to correct the interference by one or more of the following measures:

- Reorient or relocate the receiving antenna.
- Increase the separation between the equipment and receiver.
- Connect the equipment into an outlet on a circuit different from that to which the receiver is connected.
- Consult the dealer or an experienced radio/TV technician for help.

WARNING:
Changes or modifications to this equipment not expressly approved by the party responsible for compliance (Crow Electronic Engineering Ltd.) could void the user's authority to operate the equipment.

ALARM TRANSMISSION TEST

Removing and placing of magnet unit enables the alarm transmission test feature. Check that the transceiver unit indicates at least 2 events - one for removing and one for placing the magnet.

To check this function it is necessary to verify that the FREEWAVE2 control panel displays the following message:

Zone # X Open

The message appears when removing the magnet unit and disappears while placing the magnet back (X = zone number from which the message received).

REGULATORY APPROVALS

The FW2-MAG conforms to the essential requirements set out by:

- RTTE directive: 1999/5/EC
- EMC directive: 2004/108/EC
- Low Voltage directive: 2006/95/EC

Harmonized Standards applicable to this products are:

- EN300220-2
- EN301489-3
- EN301489-1
- EN50130-4
- EN61000-6-3
- EN60950-1
- EN50131-6
- EN50130-5
- EN50131-5-3

Security Grade 2 Environmental Class II

Additional Standards and Directives applicable to this product are:

- RoHS directive: 2002/95/EC
- EN50131-2-6: 2004



TECHNICAL SPECIFICATIONS

Data Protocol	FreeWave2
Modulation Type	GFSK (1 Frequency)
Frequency	868.35MHz / 868.85MHz / 916.5 MHz
Identification	Unique ID serial number - 24 bit
Event Transmission	Alarm, Tamper, Supervision, Low Bat Supervision
Detection Method	Internal Reed Switch or External Magnet Device
Range in open space	500m
Battery	Lithium. 3V Type: CR123A Size: 2/3AA
Battery life expectancy	>5 years (10 activation per day)
Current Consumptions:	
Standby	~3 µA
Receive mode	~29 mA
Transmit mode	~38 mA
Low Battery	~2.4Vdc
Transmit power:	<14dBm
Tamper Switch	Front Cover Removal; Back Tamper
External Input	Up to 15m with 8.2Kohm EOL resistor
Operating temperature	-10°C to +55°C
Dimensions	97mm x 23mm x 22mm
Weight (inc. battery)	40 gr.

CROW ELECTRONIC ENGINEERING LTD.

12 Kineret St.
Airport City, 70100 Israel
Tel. +972 3 9726000
Fax. +972 3 9726001
sales@crow.co.il
support@crow.co.il
www.thecrowgroup.com

CROW LATIN AMERICA USA INC.

7200 NW 19 st.
Suite 307
Miami FL 33126, USA
Tel. +305 513 4001
Fax. +305 513 4005
rejane@crowlatinamerica.com
www.crowlatinamerica.com

ARROWHEAD ALARM PRODUCTS

344B, Rosedale Road
Park Farm Industrial Estate
Albany, Auckland
New Zealand
Tel. +64 9 414 0085
Fax. +64 9 414 0088
www.aap.co.nz

These instructions supersede all previous issues in circulation prior to March 2012.